

# *Guide to the Use of the Wind Load Provisions of ASCE 7-02*

Kishor C. Mehta  
James Delahay

**ASCE**  
**PRESS**

Cataloging-in-publication data on file with the Library of Congress.

## Authors' Disclaimer

Although the authors have done their best to ensure that any advice, recommendation, interpretation, or information given herein is accurate, no liability or responsibility of any kind (including liability for negligence) is accepted by the authors.

Published by the American Society of Civil Engineers  
1801 Alexander Bell Drive  
Reston, VA 20191  
www.asce.org

The material presented in this publication has been prepared in accordance with generally recognized engineering principles and practices, and is for general information only. This information should not be used without first securing competent advice with respect to its suitability for any general or specific application.

The contents of this publication are not intended to be and should not be construed to be a standard of the American Society of Civil Engineers (ASCE) and are not intended for use as a reference in purchase of specifications, contracts, regulations, statutes, or any other legal document.

No reference made in this publication to any specific method, product, process, or service constitutes or implies an endorsement, recommendation, or warranty thereof by ASCE.

ASCE makes no representation or warranty of any kind, whether express or implied, concerning the accuracy, completeness, suitability, or utility of any information, apparatus, product, or process discussed in this publication, and assumes no liability therefore.

Anyone utilizing this information assumes all liability arising from such use, including but not limited to infringement of any patent or patents.

ASCE and American Society of Civil Engineers—Registered in U.S. Patent and Trademark Office.

Photocopies: Authorization to photocopy material for internal or personal use under circumstances not falling within the fair use provisions of the Copyright Act is granted by ASCE to libraries and other users registered with the Copyright Clearance Center (CCC) Transactional Reporting Service, provided that the base fee of \$18.00 per chapter plus \$.50 per page is paid directly to CCC, 222 Rosewood Drive, Danvers, MA 01923. The identification for ASCE Books is 0-7844-0703-7/04/\$18.00 + \$.50 per page. Requests for special permission or bulk copying should be addressed to Permissions & Copyright Department, ASCE.

Copyright © 2004 by the American Society of Civil Engineers.  
All Rights Reserved.

ISBN 0-7844-0703-7

Manufactured in the United States of America.

# Contents

List of Figures.....	vii
List of Tables.....	ix
Preface .....	xiii
Acknowledgments .....	xiii
<b>1. Introduction.....</b>	<b>1</b>
1.1 Objective of the Guide .....	2
1.2 Significant Changes.....	2
1.3 Limitations of Standard.....	3
1.4 Technical Literature .....	4
<b>2. Wind Load Provisions.....</b>	<b>6</b>
2.1 Format .....	6
2.2 Design Procedures.....	6
2.3 Method 3, Wind Tunnel Procedure.....	10
2.4 Equations for Graphs.....	10
<b>3. Examples.....</b>	<b>17</b>
3.1 Example 1: 30-ft × 60-ft × 15-ft Commercial Building with Concrete Masonry Unit Walls .....	18
3.2 Example 2: Ex. 1 Using Simplified Procedure.....	24
3.3 Example 3: 100-ft × 200-ft × 160-ft-High Office Building .....	26
3.4 Example 4: Office Building of Ex. 3 Located on an Escarpment .....	37
3.5 Example 5: 2,500-ft <sup>2</sup> House with Gable/Hip Roof .....	39
3.6 Example 6: 200-ft × 250-ft Gable Roof Commercial/Warehouse Building Using Buildings of All Height Provisions .....	47
3.7 Example 7: Building of Ex. 6 Using Low-Rise Building Provisions .....	59
3.8 Example 8: 40-ft × 80-ft Commercial Building with Monoslope Roof with Overhang.....	66
3.9 Example 9: U-Shaped Apartment Building .....	78
3.10 Example 10: 50-ft × 20-ft Billboard Sign on Poles (Flexible) 60 ft Above Ground.....	88
3.11 Example 11: Domed Roof Building .....	93
3.12 Example 12: Unusually Shaped Building.....	100
<b>4. Frequently Asked Questions .....</b>	<b>110</b>
References.....	119
Index.....	123

# About the Authors

**Kishor C. Mehta, P.E.**, Honorary Member of ASCE, Horn Professor of Civil Engineering, is the former Director of the Wind Science and Engineering Research Center at Texas Tech University, Lubbock, Texas. He served as Chairman of the ASCE 7 Task Committee on Wind Loads, which produced ASCE 7-88 and ASCE 7-95. He was lead author of the *Guide to the Use of Wind Load Provisions of ASCE 7-95*. Dr. Mehta is past president of the American Association of Wind Engineering and past chairman of the Committee on Natural Disasters, National Research Council. He is project director of the NSF-sponsored Colorado State University/Texas Tech University Cooperative Program in Wind Engineering and program director of the Texas Tech/National Institute of Standards and Technology Cooperative Agreement for Windstorm Damage Mitigation. In April 2000, the National Hurricane Conference honored Dr. Mehta with an award for distinguished service in wind engineering.

**James M. Delahay, P.E.**, is president/CEO of LBYD Inc., a consulting civil and structural engineering firm in Birmingham, Alabama. He is a member of the ASCE 7 Task Committee on Wind Loads, which produced ASCE 7-98 and ASCE 7-02, and is serving as Vice-Chairman for the 2005 edition. He has been a practicing structural engineer since 1981, and has held the position of principal with LBYD since 1987. His design experience includes the engineering of numerous building structures for many commercial and industrial projects throughout the United States, utilizing material types varying from steel, concrete, and masonry, to wood and aluminum. Mr. Delahay has been involved in building code development since 1991, representing the Structural Engineering Association of Alabama (SEAOAL) on the Southern Building Code Congress International (SBCCI) Wind Load Committee. He served on the International Building Code (IBC) Structural Committee from 1999 to 2002, serving as the Chairman of the committee for the 2003 IBC. Mr. Delahay has presented numerous seminars nationwide on both the IBC and ASCE wind load provisions. Venues have included ASCE Structures Congresses and Annual Conferences, NCSEA Annual Conferences, the 2001 NCSEA Winter Institute, and the jointly sponsored ICBO/NCSEA/S.K. Ghosh & Associates/SBCCI/ASCE Seminar 125i- Wind and Snow Load Provisions of the IBC 2000 that toured the United States in 2001.

# List of Figures

3-1	Building Dimensions for Examples 1 and 2.....	18
3-2	Design Pressures for MWFRS when Wind is Normal to 30-ft Wall .....	21
3-3	Design Pressures for MWFRS when Wind is Normal to 60-ft Wall .....	21
3-4	Load Case 3 .....	22
3-5	Design Wind Pressure .....	25
3-6	100-ft × 200-ft × 160-ft Building .....	27
3-7	Pressures for MWFRS for Wind Normal to the 200-ft Face .....	33
3-8	Pressures for MWFRS for Wind Normal to 100-ft Face .....	33
3-9	Pressures in Case B for MWFRS for Wind Normal to 100-ft Face .....	34
3-10	Office Building on Escarpment.....	37
3-11	a, View of Roof of 2,500-ft <sup>2</sup> House; b, Front View D; c, Side View A; d, Side View C.....	40
3-12	Combinations of Wind Directions .....	45
3-13	Dimensions and Framing of the Building of Examples 6 and 7..	48
3-14	Net Design Wind Pressures for MWFRS when Wind is Normal to Ridge with Negative Windward External Roof Pressure Coefficient .....	51
3-15	Net Design Wind Pressures for MWFRS when Wind is Normal to Ridge with Positive Windward External Roof Pressure Coefficient .....	52
3-16	Net Design Wind Pressures for MWFRS when Wind is Parallel to Ridge with Positive Internal Pressure.....	54
3-17	Net Design Wind Pressures for MWFRS when Wind is Parallel to Ridge with Negative Internal Pressure.....	55
3-18A	Combined Uplift and Axial Design Loads on Interior Strut Purlin.....	58
3-18B	Eave Strut Purlin Supports Roof and Wall Panels .....	58
3-19	Design Pressures for Transverse Direction with Positive Internal Pressure .....	62
3-20	Design Pressures for Transverse Direction with Negative Internal Pressure .....	63
3-21	Design Pressures for Longitudinal Direction with Positive Internal Pressure .....	63

3-22	Design Pressures for Longitudinal Direction with Negative Internal Pressure . . . . .	63
3-23	Torsional Load Case for Transverse Direction with Positive Internal Pressure . . . . .	64
3-24	Torsional Load Case for Transverse Direction with Negative Internal Pressure . . . . .	65
3-25	Torsional Load Case for Longitudinal Direction with Positive Internal Pressure . . . . .	65
3-26	Torsional Load Case for Longitudinal Direction with Negative Internal Pressure . . . . .	65
3-27	Dimensions of the Retail Store Strip-Mall . . . . .	66
3-28	Design Pressures for MWFRS; Wind Parallel to Roof Slope, Normal to 15-ft Wall, and Positive Internal Pressure a., External Pressures; b., Positive Internal Pressure; c., Combined External and Positive Internal Pressure . . . . .	71
3-29	Design Pressures for MWFRS; Wind Parallel to Roof Slope, Normal to 15-ft Wall and Negative Internal Pressure a., External Pressures; b., Negative Internal Pressure; c., Combined External and Negative Internal Pressure . . . . .	72
3-30	Combined Design Pressures for MWFRS; Wind Parallel to Roof Slope (Normal to 25-ft Wall) . . . . .	73
3-31	Combined Design Pressures for MWFRS; Wind Perpendicular to Roof Slope (Parallel to Ridge Line) . . . . .	73
3-32	Design Pressures for Typical Joists and Pressure Zones for Roof Components and Cladding . . . . .	77
3-33	240-ft × 170-ft U-shaped Apartment Building . . . . .	78
3-34	Surface Designations . . . . .	82
3-35	Design Wind Load Cases for Wind Normal to Wall W2 and W3 . . . . .	85
3-36	Component and Cladding Wall Pressure Zones . . . . .	87
3-37	Component and Cladding Roof Pressure Zones . . . . .	88
3-38	Dimensions of a Billboard Sign on an Interstate Highway . . . . .	89
3-39	Design Forces for the Billboard Sign . . . . .	93
3-40	100-ft Diameter Domed Roof Building . . . . .	94
3-41	MWFRS External Pressures . . . . .	97
3-42	Component Design Pressures . . . . .	99
3-43	100-ft × 100-ft Unusually Shaped Building . . . . .	100
3-44	External Roof Pressure Zones for MWFRS . . . . .	105
3-45	Application of 10-psf Minimum Load Case . . . . .	105
3-46	Application of Load Case 1 from Each Orthogonal Direction . . . . .	106
3-47	Application of Load Case 3 from Each Diagonal Direction . . . . .	107
3-48	Component and Cladding Wall Pressure Zones . . . . .	109
3-49	Component and Cladding Roof Pressure Zones . . . . .	109

# List of Tables

1-1	Technical Literature .....	5
2-1	Walls for Buildings with $h \leq 60$ ft (Figure 6-11A) .....	11
2-2	Gable Roofs with $h \leq 60$ ft, $\theta \leq 7^\circ$ (Figure 6-11B) .....	11
2-3	Gable and Hip Roofs with $h \leq 60$ ft, $7^\circ < \theta \leq 27^\circ$ (Figure 6-11C) .....	12
2-4	Gable Roofs with $h \leq 60$ ft, $27^\circ < \theta \leq 45^\circ$ (Figure 6-11D) .....	12
2-5	Multispan Gabled Roofs with $h \leq 60$ ft, $10^\circ < \theta \leq 30^\circ$ (Figure 6-13) .....	13
2-6	Multispan Gable Roofs with $h \leq 60$ ft, $30^\circ < \theta \leq 45^\circ$ (Figure 6-13) .....	13
2-7	Monoslope Roofs with $h \leq 60$ ft, $3^\circ < \theta \leq 10^\circ$ (Figure 6-14A) ...	14
2-8	Monoslope Roofs with $h \leq 60$ ft, $10^\circ < \theta \leq 30^\circ$ (Figure 6-14B) ...	14
2-9	Sawtooth Roofs with $h \leq 60$ ft (Figure 6-15) .....	15
2-10	Roofs and Walls for Buildings with $h > 60$ ft (Figure 6-17) .....	16
3-1	Design Wind Pressures .....	25
3-2	$q_z$ Velocity Pressures .....	28
3-3	Wall $C_p$ for Ex. 3 .....	29
3-4	Roof $C_p$ for Wind Normal to 200-ft Face .....	30
3-5	Roof $C_p$ for Wind Normal to 100-ft Face .....	30
3-6	External Pressures for MWFRS: Wind Normal to 200-ft Face ...	31
3-7	External Pressures for MWFRS: Wind Normal to 100-ft Face ...	31
3-8	Wall ( $GC_p$ ) for Ex. 3 .....	34
3-9	Controlling Design Pressures for Mullions (psf) .....	35
3-10	Design Pressures of Panels (psf) .....	35
3-11	Roof External Pressure Coefficient ( $GC_p$ ) .....	36
3-12	Roof Design Pressures (psf) .....	36
3-13	Speed-up Velocity Pressures (psf) .....	38
3-14	Velocity Pressure $q_z$ (psf) .....	39
3-15	Roof $C_p^*$ for Wind Direction A .....	41
3-16	Roof $C_p$ for Wind Direction B .....	43
3-17	Velocity Pressures (psf) .....	49
3-18	External Wall $C_p$ .....	50
3-19	Roof $C_p$ (Wind Normal to Ridge) .....	50

3-20	MWFRS Pressures: Wind Normal to Ridge	.51
3-21	Roof $C_p$ (Wind Parallel to Ridge)	.53
3-22	MWFRS Pressures: Wind Parallel to Ridge	.53
3-23	Wall Coefficients ( $GC_p$ ) in Figure 6-11A	.54
3-24	Net Controlling Wall Component Pressures (psf)	.55
3-25	Roof Coefficients ( $GC_p$ ) in Figure 6-11C; $7^\circ < \theta < 27^\circ$	.56
3-26	Net Controlling Roof Component Pressures (psf)	.57
3-27	Transverse Direction ( $\theta = 18.4^\circ$ )	.61
3-28	Longitudinal Direction ( $\theta = 0^\circ$ )	.61
3-29	Design Wind Pressures, Transverse Direction	.61
3-30	Design Wind Pressures, Longitudinal Direction	.61
3-31	Design Wind Pressure for Zone "T," Transverse Direction	.64
3-32	Design Wind Pressure for Zone "T," Longitudinal Direction	.64
3-33	Velocity Pressures, $q_z$ , $q_v$ and $q_h$ (psf)	.67
3-34	Wall Pressure Coefficients ( $C_p$ )	.69
3-35	Roof Pressure Coefficients ( $C_p$ )	.69
3-36	Design Pressures for MWFRS: Wind Parallel to Roof Slope (normal to ridge line)	.70
3-37	Design Pressures for MWFRS: Wind Normal to Roof Slope (parallel to ridge line)	.74
3-38	Wall External Pressure Coefficients ( $GC_p$ )	.74
3-39	Wall Design Pressures (psf)	.75
3-40	Roof External Pressure Coefficients ( $GC_p$ ), $\theta = 14^\circ$	.76
3-41	Roof Design Pressures (psf)	.76
3-42	$q_z$ Velocity Pressures	.79
3-43	External Pressure Coefficients ( $C_p$ ) for Wind Normal to Wall W2	.80
3-44	External Pressure Coefficients ( $C_p$ ) for Wind Normal to Wall W4	.81
3-45	External Pressure Coefficients ( $C_p$ ) for Wind Normal to Wall W3	.81
3-46	External Pressure Coefficients ( $C_p$ ) for Wind Normal to Wall W1-W7-W5	.81
3-47	External Pressures for Wind Normal to Wall W2	.83
3-48	External Pressures for Wind Normal to Wall W4	.84
3-49	External Pressures for Wind Normal to Wall W3	.84
3-50	External Pressures for Wind Normal to Wall W1-W7-W5	.85
3-51	Wall ( $GC_p$ ) for Ex. 9	.86
3-52	Controlling Design Pressures for Wall Components (psf)	.86
3-53	Roof External Pressure Coefficients ( $GC_p$ )	.87
3-54	Roof Design Pressures (psf)	.88
3-55	Velocity Pressures (psf)	.89
3-56	$q_z$ Velocity Pressures	.95
3-57	Domed Roof $C_p$ (at $f/D = 0.30$ )	.96

<b>3-58</b>	Interpolated Domed Roof $C_p$ (Case A) .....	96
<b>3-59</b>	Interpolated Domed Roof $C_p$ (Case B) .....	96
<b>3-60</b>	Domed Roof Design Pressures for MWFRS (psf) .....	98
<b>3-61</b>	Roof External Pressure Coefficient ( $GC_p$ ) from Figure 6-16 .....	99
<b>3-62</b>	Roof Design Pressures (psf) .....	99
<b>3-63</b>	$q_z$ Velocity Pressures .....	101
<b>3-64</b>	External Pressure Coefficients ( $C_p$ ) for Wind Normal to Wall W1 .....	102
<b>3-65</b>	External Pressure Coefficients ( $C_p$ ) for Wind Normal to Wall W5 .....	102
<b>3-66</b>	External Pressure Coefficients ( $C_p$ ) for Wind Normal to Wall W4 .....	102
<b>3-67</b>	External Pressure Coefficients ( $C_p$ ) for Wind Normal to Wall W2 .....	102
<b>3-68</b>	Design Pressures for Wind Normal to Wall W1 .....	103
<b>3-69</b>	Design Pressures for Wind Normal to Wall W5 .....	103
<b>3-70</b>	Design Pressures for Wind Normal to Wall W4 .....	104
<b>3-71</b>	Design Pressures for Wind Normal to Wall W2 .....	104
<b>3-72</b>	Wall ( $GC_p$ ) for Ex.12 .....	107
<b>3-73</b>	Controlling Design Pressures for Wall Components (psf) .....	108
<b>3-74</b>	Roof External Pressure Coefficients ( $GC_p$ ) .....	108
<b>3-75</b>	Roof Design Pressures (psf) .....	108



# Preface

This guide is designed to assist professionals in the use of the wind load provisions of SEI/ASCE Standard 7-02, *Minimum Design Loads for Buildings and Other Structures*, published by the American Society of Civil Engineers (ASCE). The guide is a revision of the *Guide to the Use of Wind Load Provisions of ASCE 7-98*, reflecting the significant changes made to wind load provisions when the previous version of the Standard, ASCE 7-98, was updated. The guide contains 12 example problems worked out in detail, which can provide direction to practicing professionals in assessing wind loads on a variety of buildings and other structures. Every effort has been made to make these illustrative example problems correct and accurate. The authors would welcome comments regarding inaccuracies, errors, or different interpretations. The views expressed and interpretation of the wind load provisions made in the guide are those of the authors and not of the ASCE 7 Standards Committee or the ASCE organization.

# Acknowledgments

The authors wish to acknowledge the members of the ASCE 7 Minimum Design Loads for Buildings and Other Structures Standards Committee that was chaired by Dr. Jim Harris during the consensus process of ASCE 7-02. The members of the Task Committee on Wind Loads and the ASCE 7 Standards Committee contributed significantly to the final wind load provisions of the ASCE 7-02 through their questions, comments, and discussions. The authors are indebted to these 100-plus members.

In a document of this type, there are individuals in the background who helped in layout, word-processing, and checking calculations. These tasks were handled by the staff of the Wind Science and Engineering Research Center, Texas Tech University, and the authors acknowledge and appreciate the contributions of these individuals. In particular, we would like to thank Hua He, doctoral degree candidate at Texas Tech University, who performed and checked calculations for example problems and made a significant contribution to this guide; and Kevin Brown, project engineer at LBYD, Inc., who back-checked the calculations for all the example problems. The authors acknowledge and appreciate the contributions of all these individuals.



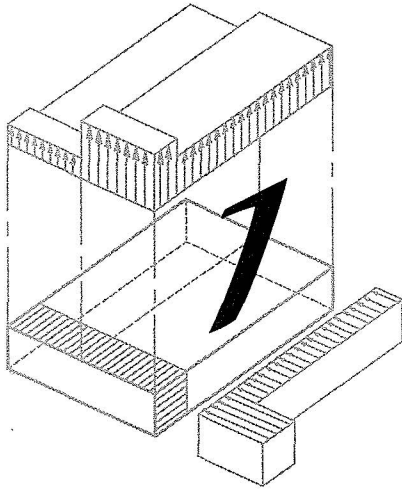

# Introduction

The American Society of Civil Engineers (ASCE) publication, SEI/ASCE Standard 7-02, *Minimum Design Loads for Buildings and Other Structures*, is a consensus standard. It originated in 1972 when the American National Standards Institute (ANSI) published a standard with the same title (ANSI A58.1-1972). That 1972 standard was revised 10 years later, containing an innovative approach to wind loads for components and cladding (C&C) of buildings (ANSI A58.1-1982). Wind load criteria were based on the understanding of aerodynamics of wind pressures in building corners, eaves, and ridge areas, as well as the effects on pressures of area averaging.

In the mid-1980s, the ASCE assumed responsibility for the Minimum Design Loads for Buildings and Other Structures Standards Committee, which establishes design loads. The document published by ASCE (ASCE 7-88) contained design load criteria for live loads, snow loads, wind loads, earthquake loads, and other environmental loads, as well as load combinations. The ASCE 7 Standards Committee has voting membership of close to 100 individuals representing all aspects of the building construction industry. The criteria for each of the environmental loads are developed by respective task committees.

The wind load criteria of ASCE 7-88 (ASCE, 1990) were essentially the same as ANSI A58.1-1982. In 1995, ASCE published ASCE 7-95. This version contained major changes in wind load criteria: the basic wind speed averaging time was changed from fastest-mile to 3-second gust. This in turn necessitated significant changes in boundary-layer profile parameters, gust effect factor, and some pressure coefficients. A *Guide to the Use of the Wind Load Provisions of ASCE 7-95* (Mehta and Marshall, 1998) was published by ASCE to assist practicing professionals in the use of wind load criteria of ASCE 7-95.

In 2000, ASCE published a revision of ASCE 7-95 with updated wind load provisions. The document is termed ASCE 7-98 and has the same title (ASCE, 2000). The International Building Code (ICC 2000) adopted the wind load criteria of ASCE 7-98 by reference. This was a major milestone

since it had the potential to establish a single wind load criterion for design of all buildings and structures for the entire United States. A *Guide to the Use of the Wind Load Provisions of ASCE 7-98* (Mehta and Perry, 2000) was published soon after publication of ASCE 7-98.

In 2003, the new standard, ASCE 7-02, was published. This guide is designed to assist practicing professionals in the use of wind load criteria of ASCE 7-02.

## 1.1 Objective of the Guide

The objective of this guide is to provide direction in the use of wind load provisions of ASCE 7-02 (referred to as “the Standard”). The Commentary of ASCE 7-02 (Section C6.0) contains a good background and discussion of the wind load criteria; that information is not repeated in this document. Rather, this guide contains two important items to assist the users of ASCE 7-02: (1) examples, and (2) Frequently Asked Questions.

The guide contains 12 worked examples. Sufficient details of calculation of wind loads are provided to help the reader properly interpret the wind load provisions of the Standard. Section 6.0 of the Standard, as well as the figures and tables of the Standard, are cited liberally in the examples. **It is necessary to have a copy of ASCE 7-02 to follow the examples and work with this Guide.** A copy of ASCE 7-02 can be ordered by calling 1-800-548-ASCE or ordered on the web at [www.pubs.asce.org](http://www.pubs.asce.org).

## 1.2 Significant Changes

The wind load provisions of Section 6.0 were revised in ASCE 7-02 using recent research and development achievements. The major changes involve expansion of the simplified procedure, load cases for main wind force-resisting systems (MWFRS), and introduction of surface roughness length to define exposure coefficients.

The basic approach to assessing wind loading has not been changed, but new parameters, such as surface roughness length, are added to provide more flexibility to designers. In addition, wind-borne debris provisions in hurricane-prone areas are specifically spelled out. Significant changes affecting the design process are listed below.

- Method 1, Simplified Procedure, is significantly revised and expanded. The requirements for using this method have been set separately for MWFRS and components and cladding (C&C). The procedure is expanded to include flat, gable, and hip roofs with roof slope up to 45° MWFRS. For C&C, the hip roof is restricted to  $\theta = 27^\circ$ . Eq. 6-1 and 6-2 permit modification for terrain and height from tabulated values, as well as for importance factor.
- For design of MWFRS, wind load cases (Figure 6-9) are applied to buildings of all heights.
- Exposure category is based on surface roughness length in each wind direction sector. The surface roughness length parameter permits interpolation of the exposure category using a rational proce-