



ATIS-0600036

ATIS Standard on -

Electrical Protection for Ethernet Systems



As a leading technology and solutions development organization, the Alliance for Telecommunications Industry Solutions (ATIS) brings together the top global ICT companies to advance the industry's most pressing business priorities. ATIS' nearly 200 member companies are currently working to address the All-IP transition, 5G, network functions virtualization, big data analytics, cloud services, device solutions, emergency services, M2M, cyber security, network evolution, quality of service, billing support, operations, and much more. These priorities follow a fast-track development lifecycle — from design and innovation through standards, specifications, requirements, business use cases, software toolkits, open source solutions, and interoperability testing.

ATIS is accredited by the American National Standards Institute (ANSI). The organization is the North American Organizational Partner for the 3rd Generation Partnership Project (3GPP), a founding Partner of the oneM2M global initiative, a member of and major U.S. contributor to the International Telecommunication Union (ITU), as well as a member of the Inter-American Telecommunication Commission (CITEL). For more information, visit www.atis.org.

Notice of Disclaimer & Limitation of Liability

The information provided in this document is directed solely to professionals who have the appropriate degree of experience to understand and interpret its contents in accordance with generally accepted engineering or other professional standards and applicable regulations. No recommendation as to products or vendors is made or should be implied.

NO REPRESENTATION OR WARRANTY IS MADE THAT THE INFORMATION IS TECHNICALLY ACCURATE OR SUFFICIENT OR CONFORMS TO ANY STATUTE, GOVERNMENTAL RULE OR REGULATION, AND FURTHER, NO REPRESENTATION OR WARRANTY IS MADE OF MERCHANTABILITY OR FITNESS FOR ANY PARTICULAR PURPOSE OR AGAINST INFRINGEMENT OF INTELLECTUAL PROPERTY RIGHTS. ATIS SHALL NOT BE LIABLE, BEYOND THE AMOUNT OF ANY SUM RECEIVED IN PAYMENT BY ATIS FOR THIS DOCUMENT, AND IN NO EVENT SHALL ATIS BE LIABLE FOR LOST PROFITS OR OTHER INCIDENTAL OR CONSEQUENTIAL DAMAGES. ATIS EXPRESSLY ADVISES THAT ANY AND ALL USE OF OR RELIANCE UPON THE INFORMATION PROVIDED IN THIS DOCUMENT IS AT THE RISK OF THE USER.

NOTE - The user's attention is called to the possibility that compliance with this standard may require use of an invention covered by patent rights. By publication of this standard, no position is taken with respect to whether use of an invention covered by patent rights will be required, and if any such use is required no position is taken regarding the validity of this claim or any patent rights in connection therewith. Please refer to [<http://www.atis.org/legal/patentinfo.asp>] to determine if any statement has been filed by a patent holder indicating a willingness to grant a license either without compensation or on reasonable and non-discriminatory terms and conditions to applicants desiring to obtain a license.

Published by

Alliance for Telecommunications Industry Solutions
1200 G Street, NW, Suite 500
Washington, DC 20005

Copyright © 2017 by Alliance for Telecommunications Industry Solutions
All rights reserved.

No part of this publication may be reproduced in any form, in an electronic retrieval system or otherwise, without the prior written permission of the publisher. For information contact ATIS at 202.628.6380. ATIS is online at < <http://www.atis.org> >.

Electrical Protection for Ethernet Systems

Alliance for Telecommunications Industry Solutions

Approved March 16, 2017

Abstract

The purpose of this ATIS Standard is to assist the service provider in choosing appropriate protection methods for Ethernet communications circuits. This ATIS Standard describes protector characteristics that may impact Ethernet systems for outside plant, intra- and inter-building applications, and the services provided over these links. These protectors are categorized by technology type and configurations. This document describes protectors in their non-operating state and their effect on these services, and also considers the effects of protector response to a surge event and how that operation may affect these services. This is a subtending document and is intended to be used with the Broadband umbrella document ATIS-0600012, *Electrical Protection Considerations for Broadband Systems*.

Foreword

The Alliance for Telecommunication Industry Solutions (ATIS) serves the public through improved understanding between providers, customers, and manufacturers. The Sustainability in Telecom: Energy and Protection (STEP) Committee – formerly the Network Interface, Power, and Protection (NIPP) Committee – engages industry expertise to develop standards and technical reports for telecommunications equipment and environments in the areas of energy efficiency, environmental impacts, power, and protection. The work products of STEP enable vendors, operators, and their customers to deploy and operate reliable, environmentally sustainable, energy efficient communications technologies. STEP is committed to proactive engagement with national, regional, and international standards development organizations and forums that share its scope of work.

The mandatory requirements are designated by the word shall and recommendations by the word should. Where both a mandatory requirement and a recommendation are specified for the same criterion, the recommendation represents a goal currently identifiable as having distinct compatibility or performance advantages. The word may denotes an optional capability that could augment the standard. The standard is fully functional without the incorporation of this optional capability.

Suggestions for improvement of this document are welcome. They should be sent to the Alliance for Telecommunications Industry Solutions, STEP, 1200 G Street NW, Suite 500, Washington, DC 20005.

At the time it approved this document, STEP, which is responsible for the development of this Standard, had the following leadership:

- J. Krahnert, Cisco, STEP Vice-Chair (Cisco)
- J. Fuller, NEP Chair (AT&T)
- E. Gallo, NEP Vice Chair (Ericsson)

The Network Electrical Protection (NEP) Subcommittee was responsible for the development of this document.

Table of Contents

1	Scope, Purpose, & Application.....	6
1.1	Scope.....	6
1.1.1	<i>Electrical Protection</i>	6
1.1.2	<i>Equipment Covered</i>	6
2	References.....	6
3	Definitions, Acronyms, & Abbreviations.....	8
3.1	Definitions.....	8
3.2	Acronyms.....	9
4	Description of Ethernet.....	10
4.1	Standard Ethernet.....	11
4.2	Power over Ethernet (PoE).....	14
4.2.1	<i>Mode A</i>	16
4.2.2	<i>Mode B</i>	17
5	Single Pair PoE.....	23
6	Alternative 4 pair Simultaneous PoE Connection Types.....	24
7	Ethernet Protection Topologies.....	27
7.1	Grounding & Bonding of Ethernet Cable Shields.....	28
7.2	Service to Cell Towers.....	28
7.2.1	<i>Conductor-to-Conductor (Differential)</i>	29
7.3	Mitigation of Lightning Induced Surges.....	31
7.4	Tertiary Protection vs. Line Side Protection.....	32
7.4.1	<i>Tertiary Protection Advantages</i>	32
7.4.2	<i>Tertiary Protection Disadvantages</i>	32
7.4.3	<i>Line Side Protection Advantages</i>	32
7.4.4	<i>Line Side Protection Disadvantages</i>	32
7.5	PoE Protection.....	33
8	Data Line Protection.....	34
8.1	Low-Level Lightning, ESD & EFT Indoor Short-Haul.....	34
8.2	Lightning, ESD, EFT, Power Fault, Indoor Long-Haul.....	34
8.3	Line Side Ground Referenced Protection Issues.....	36
8.4	High Voltage Isolation (Lightning GPR).....	37
8.5	Capacitor Isolation.....	41
8.6	Port to Port Protection.....	41
9	Ethernet Deployment Scenarios & Test Requirements.....	42
9.1	Port to Port Testing.....	58
10	ESD Testing (IEC 61000-4-2).....	60
11	Electrical Fast Transient (EFT) Testing (IEC 61000-4-4).....	60
	Annex A: Ethernet Bandwidths & Voltages.....	62
	Annex B: Grounding of Cables.....	68

B.1 Terminating Screens at Both Ends to Control RF	68
B.2 Potential Issues When Systems are Terminated at Only One End	70
B.3 The Parallel Earth Conductor (PEC)	71
B.4 When Cable Screens Cannot Be Terminated at Both Ends:	73
B.5 Copper Communications between Buildings.....	74
Annex C: Updates regarding PoE	75
Annex D: Magnetically Induced Currents & Voltages in Ethernet Cable	76
D.1 Introduction	76
D.2 Magnetic coupling	76
D.2.1 Currents in Low Impedance Loops	76
D.2.2 Voltages in high impedance loops	77
D.3 Waveshapes	79
D.3 Circuit Conditions During Induced Lightning Voltage Events	80
D.3.1 Balanced Conditions	80
D.3.2 SPD Added to One Port	80
D.3.3 SPDs on Both Ports	81
D.4 Other Stress Factors	81
D.4.1 Ethernet SPD Operation	81
D.5 Summary.....	85

Table of Figures

Figure 4.1 – Ethernet Jacks	11
Figure 4.2 – Eye Patterns for Ethernet Signals.....	13
Figure 4.3 – Mode A for 10/100Base T	17
Figure 4.4 – Mode B for 10/100BASE-T	18
Figure 4.5 – Mode A for 1000BASE-T	19
Figure 4.6 – Mode B for 1000BASE-T	20
Figure 4.7 – PoE++ for 1000BASE-T	21
Figure 4.8 – PoE++ for 10/100Base-T.....	22
Figure 5.1 – General Block Diagram for Single Pair PoE	23
Figure 6.1 – 10/100BASE-T 4 Pair PoE (Alt A + Alt B) top and bottom lines are not signal pairs	24
Figure 6.2 – 1000BASE-T and 10GBASE-T 4 Pair PoE (Alt A + Alt B).....	25
Figure 7.1 – Tertiary Differential Protection Example	30
Figure 7.2 – External Differential Ethernet Protection Example	31
Figure 8.1 – Typical Diode Bridge Schematics.....	34
Figure 8.2 – Powered Device End (PD) exposed to simultaneous longitudinal surge	35
Figure 8.3 – Power Sourcing Equipment (PSE) Exposed Simultaneous Longitudinal Surge	36
Figure 8.4 – Single End Protection Deficiency	37
Figure 8.5 – Secondary Peak Current vs. Primary Current (8/20 μ s).....	39
Figure 8.6 – Secondary Current vs. Primary Current CW 1.2/50 μ s, 8/20 μ s, and 2/10 μ s	39
Figure 8.7 – Primary and secondary current waveforms of transformer B	40
Figure 8.8 – High Impulse Isolation Ethernet Circuit Example	41
Figure 8.9 – Port to Port Protection	42
Figure 9.1 – PoE Ethernet Testing	49
Figure 9.2 – Shielded Cable Testing	50

Figure 9.3 – Shield Bonding Testing	50
Figure 9.4 – Ethernet Insulation Testing.....	51
Figure 9.5 – Ethernet Isolation Testing.....	52
Figure 9.6 – Common mode simultaneous 10/360 test condition	53
Figure 9.7 – 50/60Hz common mode test setup change generator to same as in Figure 9.8.....	55
Figure 9.8 – Simultaneous 1.2/50-8/20 common mode surge test.....	57
Figure 9.9 – Metallic Surge Testing.....	58
Figure 9.10 – External port to external port surge test setup	59
Figure 9.11 – External port to internal port surge test setup	59
Figure 9.12 – Internal port to internal port surge test setup	60
Figure A.1 – 1000BASE-T (1GbE)	63
Figure A.2 – 100BASE-T.....	63
Figure B. 1 – 360° screening from end to end	69
Figure B.2 – Ground Potential Rise in Single-Point Earthing System	71
Figure B.3 – Examples of PECs.....	73
Figure D.1 – Induced lightning current waveshape in a low-impedance loop.....	77
Figure D.2 – Induced lightning voltage waveshape in a high-impedance loop.....	77
Figure D.3 – Coupling between two negligible diameter parallel wires of equal length	78
Figure D.4 – Induced lightning voltage in cable	79
Figure D.5 – Induced loop current and voltage waveshapes for 8/20 current	79
Figure D.6 – Induced loop current and voltage waveshapes for 1/32 current	79
Figure D.7 – Ethernet twisted pair induced voltage situation	80
Figure D.8 – Equipment port voltages in a balanced situation	80
Figure D.9 – Voltage levels with a single SPD.....	81
Figure D.10 – SPDs on both ports operated by GPR	81
Figure D.11 – SPD with high and low impedance differential terminations	82
Figure D.12 – SPD common mode to differential-mode surge conversion.....	82
Figure D.13 – 3-electrode and 2-electrode GDT operation.....	83
Figure D.14 – Separate GDTs and low impedance termination.....	84
Figure D.15 – Soil GPR surrounding a lightning stroke	85
Figure D.16 – Possible cable voltage conditions of clause 4 for lightning induced voltages in a home networking Optical Network termination.....	86

Table of Tables

Table 6.1 – Temperature Rise vs Maximum Steady-State Current.....	26
Table 6.2 – PoE Parameters	26
Table 9.1 – Low Exposure Environment.....	44
Table 9.2 – High Exposure Environment.....	45
Table 9.3 – Surge Test Conditions	46
Table 9.4 – Power Fault Testing Conditions.....	48

ATIS Standard on –

Electrical Protection for Ethernet Systems

1 Scope, Purpose, & Application

1.1 Scope

1.1.1 Electrical Protection

The purpose of this ATIS Standard is to assist the service provider in choosing appropriate protection methods for Ethernet communications circuits. This ATIS Standard describes protector characteristics that may impact Ethernet systems for outside plant, intra- and inter-building applications, and the services provided over these links. These protectors are categorized by technology type and configurations. This document describes protectors in their non-operating state and their effect on these services, and also considers the effects of protector response to a surge event and how that operation may affect these services. This is a subtending document and is intended to be used with the Broadband umbrella document ATIS-0600012, *Electrical Protection Considerations for Broadband Systems*.

1.1.2 Equipment Covered

This ATIS Standard applies to the electrical protection at all Ethernet network equipment locations. Examples include: Ethernet equipment at Central Office (CO) Type facilities, remote sites, and at the customer location [including the entrance or interface point, and Customer Premises Equipment (CPE)]. This equipment may interface with various types of cable media, such as coaxial cable or twisted pair that provides the Ethernet signal and possible power.

Although a variety of existing and proposed Ethernet equipment types are considered, the merits of the different technologies, and/or architecture types, are not covered.

The following are examples of equipment/items included in this ATIS standard:

- Primary protectors.
- Secondary protectors.
- CO equipment.
- Remote terminal equipment.
- Cell Site equipment.
- NIDs, iNIDs, NIUs, ONTs, ONUs, BETs, and other points of demarcation.
- CPE such as Set-Top Boxes (STBs), xDSL splitters, telephones, etc.
- Traffic security cameras, WiFi, Wi-max, and hot spots.

2 References

The following standards contain provisions that, through reference in this text, constitute provisions of this ATIS Standard. At the time of publication, the editions indicated were valid. All standards are subject to revision, and parties to agreements based on this ATIS Standard are encouraged to investigate the possibility of applying the most recent editions of the standards indicated below.

ATIS-0600012, *Electrical Protection Considerations for Broadband Systems*.¹

¹ This document is available from ATIS at: < <https://www.atis.org/docstore/product.aspx?id=25717> >.

IEEE Std 487, *Recommended Practice for the Protection of Wire-Line Communication Facilities Serving Electric Power Locations*.²

IEEE 802.3xx, *IEEE Standard for Information technology — Telecommunications and information exchange between systems— Local and metropolitan area networks*.²

IEC/EN/UL 60950-1, Second Edition, *Information Technology Equipment - Safety - Part 1: General Requirements*, December 2011.³

IEC/EN/UL 62368-1 Edition 2, *Audio/Video, Information Technology Equipment-Safety-Requirements*.³

IEC TR-62102, *Classification of Interfaces for Equipment to be Connected to Information and Communications Technology Networks-Second Edition, 2005-05*, May 2005.³

IEEE C62.41.2, *IEEE Recommended Practice on Characterization of Surges in Low-Voltage (1000V and less) AC Power Circuits*, 2002.²

ITU K.20 *Resistibility of telecommunication equipment installed in a telecommunication center (4/2015 version)*.⁴

ITU K.21 *Resistibility of telecommunication equipment installed in customer premises (4/2015)*.⁴

ITU K.45 *Resistibility of telecommunication equipment installed in the access and trunk networks (4/2015)*.⁴

ITU K.44 *Resistibility tests for telecommunication equipment exposed to over voltages and overcurrents – Basic Recommendation (5/2012)*.⁴

GR-974-CORE, *Generic Requirements for Telecommunication Line Protector Units (TLPUs)*, Issue 4, December 2010.⁵

GR-1089-CORE, *Electromagnetic Compatibility (EMC) and Electrical Safety – Generic Criteria for Network Telecommunications Equipment*, Issue 6, May 2011.⁵

GR-3154-CORE, *Generic Requirements for High Density Feeder Distribution Interconnection and Surge Protection Telcordia Technologies Generic Requirements Issue 1*, January 2009.⁵

NFPA 70, *National Electrical Code (NEC) 2014*.⁶

IEC/TR 61000-5-6 Ed 1.0 2002-06-05, *Electromagnetic compatibility (EMC) – Part 5-6: Installation and Mitigation guidelines-mitigation of external EM influences*.³

ANSI/TIA-568-C 08/14/2012, *Generic Telecommunications Cabling For Customer Premises*.⁷

IEC 61000-4-2 Ed 2.0 2008-12 *Testing and measurement techniques – Electrostatic discharge immunity test*.³

IEC/TR 61000-4-4 Ed 2.0 2004-07 *Testing and measurement techniques – Electrical fast transient/burst immunity test*.³

² This document is available from the Institute of Electrical and Electronics Engineers (IEEE) at:
< <http://standards.ieee.org/> >.

³ This document is available from the International Electrotechnical Commission at:
< <http://www.iec.ch/standardsdev/> >.

⁴ This document is available from the International Telecommunications Union. < <http://www.itu.int/ITU-T/> >

⁵ These documents are available from Telcordia Technologies, Inc., dba iconectiv at:
< <http://www.commonlanguage.com/> >.

⁶ This document is available from the National Fire Protection Association (NFPA) at: < <http://www.nfpa.org/codes-and-standards> >.

⁷ This document is available from the Telecommunications Industry Association (TIA) at:
< <http://www.tiaonline.org/standards/overview.cfm> >.

3 Definitions, Acronyms, & Abbreviations

For a list of common communications terms and definitions, please visit the *ATIS Telecom Glossary*, which is located at < <http://www.atis.org/glossary> >.

3.1 Definitions

3.1.1 Cable Discharge Event (CDE): An ESD type event caused when a cable is connected; the initial cable charge may be caused by triboelectric (friction) effects that may occur as enhanced CAT5/5e or CAT6 cables that exhibit low leakage are dragged across a floor/carpet or simply having air movement across them or induction from adjacent electromagnetic fields. Their low leakage causes them to retain these charges for long periods of time.





3.1.2 Diode: A semi-conductor device that conducts current in only one direction under normal conditions.

3.1.3 Earth: See ground definition.

3.1.4 Electrical Fast Transient (EFT): Events that have high amplitude, short rise time, high repetition rate, and low energy content as described in IEC 61000-4-4; typically 5ns rise time, with a duration of 50ns in 15 ms bursts.

3.1.5 Ground: Identified ground (user defined as analog/digital/signal/logic, etc.). Earth ground is often used in schematics as signal ground or identified ground.

Ground Symbol Legend

	earth ground
	Protective earth ground
	Chassis ground
	Isolated ground
	Identified ground

3.1.6 High Exposure Environment: See Clause 9 for explanation.

3.1.7 Internal Ethernet Port: Ethernet port that remains within the building (see External Ethernet Port) or does not extend beyond a short distance from the building (for example, the distance from an optical network terminal (ONT) port(s) to the entrance point of the served building).

3.1.8 Low Exposure Environment: See Clause 9 for explanation.

3.1.9 PHY: The "Physical interface" Integrated Circuit that drives and receives the Ethernet signal through or from the transformer to the line. A PHY chip (PHYceiver) is commonly found on Ethernet devices. Its purpose is physical, analog signal access to the link. It is usually used in conjunction with a Media Independent Interface (MII) chip or interfaced to a microcontroller that takes care of the higher layer functions.

3.1.10 Saturation (transformer): A condition wherein additional input voltage or current results in no additional output from the transformer.

3.1.11 Secondary Protection: Overvoltage protection typically located on the cable side of the signal transformer (If an overcurrent protector is used, the secondary overvoltage protector should be between the OCP and the signal transformer.) Other standards may define secondary protectors differently.

3.1.12 Tertiary Protection: Overvoltage protection typically located between the coupling transformer and the line driver (Ethernet PHY in this document).

3.2 Acronyms

AC	Alternating Current
ANSI	American National Standards Institute
ATIS	Alliance for Telecommunications Industry Solutions
Arms	Root Mean Squared Amperes
BET	Building Entrance Terminal
CBN	Common Bonding Network (also known as an integrated ground plane)
CDE	Cable Discharge Event
CO	Central Office
CPE	Customer Premises Equipment
CRC	Cyclic Redundancy Check
dB	Decibel
DUT	Device Under Test (aka EUT)
DC	Direct Current
ECL	Electronic Current Limiter
EMI	Electromagnetic Interference
EPR	Earth Potential Rise
EFT	Electrical Fast Transient
ESD	Electrostatic Discharge Event
EUT	Equipment Under Test (aka DUT)
GbE	Gigabit Ethernet
GPR	Ground Potential Rise
HV	High Voltage
Hz	Hertz
IEEE	Institute of Electric and Electronic Engineers
kHz	Kilohertz
LAN	Local Area Network
MLT	Multi-Level Transition

NID	Network Interface Device
NRZ	Non-return-to-zero
OCP	Overcurrent protector
ONT	Optical Network Termination
ONU	Optical Network Unit
OSP	Outside Plant
PAM	Pulse Amplitude Modulation
PCB	Printed Circuit Board
PEC	Parallel Earth Conductor
PoDL	Power over Data Lines
PoE	Power over Ethernet
POTS	Plain Old Telephone Service
rms	Root-Mean-Square
RF	Radio Frequency
RT	Remote Terminal
SAD	Silicon Avalanche Diode
SELV	Safety Extra Low Voltage (from safety documents IEC/EN/UL 60950-1)
SIPO	Serial In Parallel Out
SNR	Signal-to-Noise Ratio
SPA	Silicon Protection Array
STB	Set-Top Box
STP	Shielded Twisted Pair
TIA	Telecommunications Industry Association
TNV	Telecommunication Network Voltage (from safety documents IEC/EN/UL 60950-1)
TSTC	Telecommunication Safety Technical (IEEE) Committee
TVS	Transient Voltage Suppressor
UL	Underwriters Laboratories
UPS	Uninterruptable Power Supply
UTP	Unshielded Twisted Pair
VDC	Volts of Direct Current
Vrms	Root Mean Squared Voltage
xDSL	Digital Subscriber Line
ZOI	Zone of Influence

4 Description of Ethernet

Ethernet was originally designed as an intra-building computer data interface used for interconnect and LAN applications transported by coaxial cabling in a star or ring configuration. IEEE 802.3xx standards cover the various types of Ethernet configurations. There are two types of Ethernet circuits:

- Digital signals with no dc power.
- Digital signals with dc power (PoE).

4.1 Standard Ethernet

Today, Ethernet generally is transported via Category 5 or higher twisted pair cable, usually unshielded. Traditionally the common form of Ethernet was 10 or 100BASE-T (which translated into 10 or 100 megabit data rates). More modern versions have GigE and 10GigE capabilities (Gigabit and 10 Gigabit data rates. Base stands for Baseband signaling, T stands for twisted pair, 10 = 10 Mbps, 100 = 100 Mbps, 1000 = 1000 Mbps, 10G = 10Gbps.) All the standards use either UTP (Unshielded Twisted Pair) or STP (Shielded Twisted Pair) wiring or cabling such as CAT3, CAT5, CAT5e, CAT6, CAT6a, and CAT7. Ethernet connections are typically made with an 8-pin, IEC 60603-7 8P8C modular connector (often referred to as an RJ45 type connector). Although CAT6 cable can terminate in an RJ45 modular connector that was designed for lower-grade categories, deploying these connectors will limit the overall system performance below the capability of the CAT 6 cable. There are specific connectors designed to complement the CAT6 performance. When CAT6 performance is required, only CAT6 cables and CAT6-developed connectors shall be used.

Figure 4.1 below shows the two different connector designs certified by the Telecommunications Industry Association (TIA). When the equipment being connected requires straight through Ethernet cabling, typically both ends of the cable terminate in T568B plugs. If a crossover cable (transmit and receive pairs are crossed) is used, one end of the cable uses a T568B connector, and the other end uses a T568A. In Figure 4.1 below, pins are numbered left to right, 1-8. In both T568A and T568B, for 10/100BASE-T, transmit is on Pair 3, and receive is on Pair 2, while Pairs 1 and 4 are unused for data. For 1000BASE-T (GigE) and 10GigE, all 4 pairs are used and are bi-directional (see ANSI/TIA-568C).

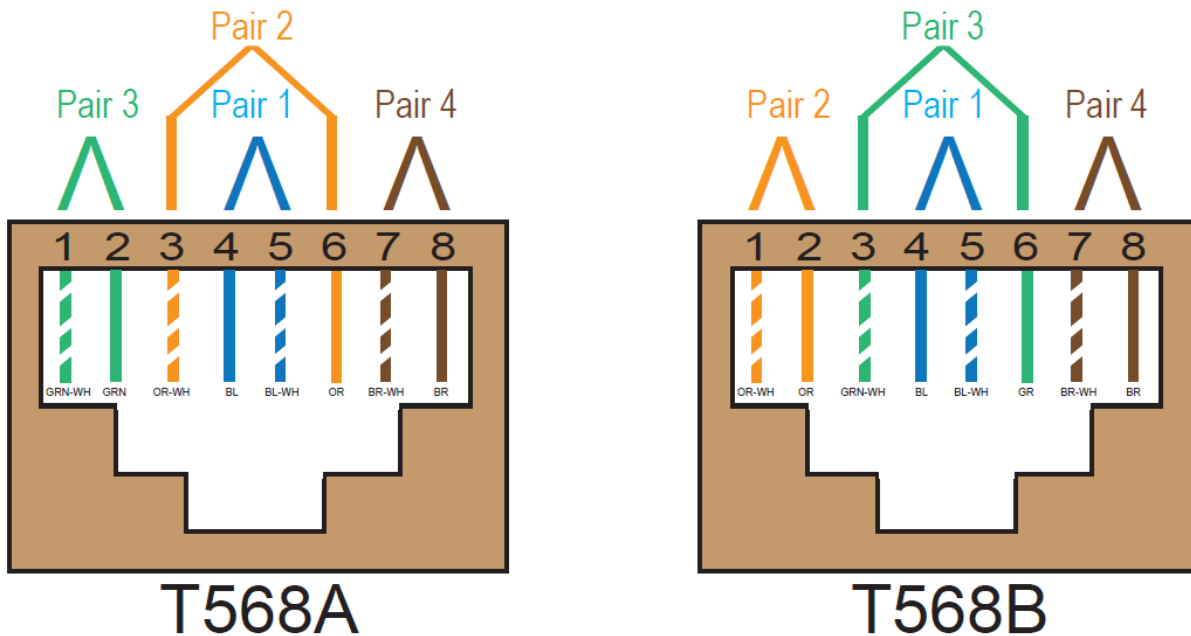

Figure 4.1 – Ethernet Jacks

A summary of 10BASE-T, 100BASE-T, 1000BASE-T and 10GbE is provided below.

10BASE-T	
Data Rate	10 Mbps
Symbol Rate	20Mbaud with 0.5bits/ baud

ATIS-0600036

Data Pairs	2 wire pairs out of the 4 wire pair available are used (1 for transmit and 1 for receive)
Signaling	Differential (i.e., 2 levels)
Encoding	4B5B NRZ Manchester (four bits are scrambled and sent as a 5 bit sequence)
Cabling	CAT3 or higher up to 100M

100BASE-T (also known as Fast Ethernet)	
Data Rate	100 Mbps
Symbol Rate	125Mbaud with 0.8bits/ baud
Data Pairs	2 wire pairs out of the 4 wire pair available are used (one wire pair for transmit and one wire pair for receive)
Signaling	Differential with MLT-3 (Multi Level Transition)
Encoding	4B5B NRZ Manchester (four bits are scrambled and sent as a 5 bit sequence)
Cabling	CAT5 or higher up to 100M

1000BASE-T	
Data Rate	1000 Mbps
Symbol Rate	125Mbaud with 2bits/ baud
Data Pairs	4 pairs (full duplex) each pair carries 250 Mbps
Signaling	Differential PAM-5 (Pulse Amplitude Modulation five-level) signaling
Encoding	8B/10B
Cabling	Preferably CAT5e or higher up to 100M

10GBASE-T (10GbE)	
Data Rate	10 Gbps
Symbol Rate	800M symbols/s
Data Pairs	4 pairs (full duplex)
Signaling	Differential PAM-16 (Pulse Amplitude Modulation sixteen-level) signaling with CRC-8
Encoding	DSQ128 (yields 3.5 bits per symbol)
Cabling	Preferably CAT6 up to 55M or CAT6A/7 up to 100M

In general, the signaling scheme becomes more complex as the data rates increase. Figure 4.2 shows the differences in eye diagrams between a 100BASE-T and 1000BASE-T signal. The ordinate (y-axis) is a normalized value to fit a ± 1 scale. In the physical world, the maximum Ethernet signals are single-ended 0-5 volts on the PHY side but typically much lower (2 -3.3 volts).

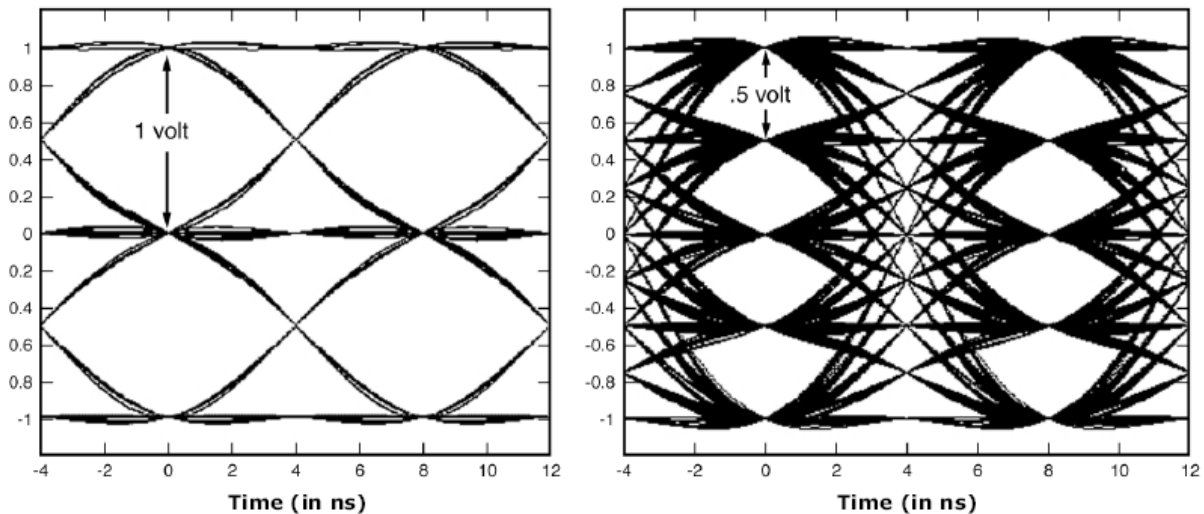

Figure 4.2 – Eye Patterns for Ethernet Signals

Ethernet was originally used in data centers and the business environment to network computers (LANs). Standard Ethernet technologies have a loop length of approximately 100 meters. But newer proprietary technologies and repeatered Ethernet may extend that range and/or reduce the number of pairs required to attain the same data rates.

Residential deployments may include intra-building connections between data and video equipment as well as service to outbuildings, exposing the Ethernet equipment to lightning and power contact. Residential deployments increase possible exposure to overvoltages from AC distribution wiring in walls compared to a business environment, as well as lightning induced surges in intra-building wiring.

In recent years, Ethernet technologies have become major transmission mediums for telecommunications networks to provide backhaul at cell sites, subscriber drops from cabinet or Optical Network Terminal (ONT), security cameras, Smartgrid devices, IP Phones, Video, and a variety of new and ever evolving telecommunication applications. Ethernet originally was not exposed to significant electrical transient activity, but with new outside plant (OSP) applications and home networking, electrical transients are becoming very common on these interfaces, and protection is becoming a requirement.

As a result of the potential electrical transients and/or AC voltage exposure, various Standards Development Organizations (SDOs) are developing requirements to address expanding Ethernet circuit applications. Examples of such work include:

- IEEE 802.3xx

All standards in this suite of standards include an isolation test requirement intended to mitigate the effects of longitudinal voltages on the interfaces such as CDEs, GPRs, lightning induced surges, and EFTs.

- IEC TR-62102

This document helps determine the level of exposure an Ethernet interface might experience. Its relevance to this standard is summarized and interpreted as follows:

IEC TR-62102 establishes a distinction in Ethernet interfaces according to environmental exposure. The low-risk for transients environment is designated “Network Environment 0” while the higher risk for transients environment is designated “Network Environment 1”. If an Ethernet signal is within SELV limits and is exposed to transients in a Network Environment 1, then it must be re-categorized as a TNV1 signal.

Network Environment 0 (typically very short-haul intra-building applications) applies only if all of the following conditions exist:

- Nearby lightning activity has little or no effect on the interface.
- An equipotential bonding system is in place to reduce the possibility of different ground potentials from lightning GPR at the endpoints. For example, all ground references are bonded via adequately sized conductors to a common grounding electrode system and the structure has only a single AC service entrance.
- Potential power fault conditions between interface conductors and power lines are limited to reduce the possibility of a power fault on the interface. For example, 120 Vrms power fault conditions may be more likely in residential applications but less likely in commercial or business applications with improved electrical code adherence.
- Interface cables are not placed in close proximity to power lines, to reduce or prevent the possibility of induced transients from the power line to the interface.

Network Environment 1 exists if one or more of these requirements are not fulfilled.

Effective with Issue 6, GR-1089-CORE addresses the criteria for intra-building Ethernet interfaces (Type 2, Type 4, and Type 4a), outside plant exposure Ethernet interfaces (Type 3b and Type 5b), and certain Ethernet applications at cell sites (Type 3a and Type 5a).

The following recommendations call for simulated lightning, ESD, and/or EFT, testing for Ethernet interfaces:

- ITU K.20 *Resistibility of telecommunication equipment installed in a telecommunication center.*
- ITU K.21 *Resistibility of telecommunication equipment installed in customer premises.*
- ITU K.45 *Resistibility of telecommunication equipment installed in the access and trunk networks.*
- ITU K.44 *Resistibility tests for telecommunication equipment exposed to overvoltages and overcurrents – Basic Recommendation.*

Various safety standards also have test conditions that apply to Ethernet interfaces:

- IEC/ 62368-1 Ed. 2.0, *Audio/Video, Information Technology Equipment-Safety-Requirements.*

This safety standard provides testing in clause 6 for interfaces that are determined to have exposure to Environment 1 based on IEC TR-62102.

- IEC/EN/UL 60950-1 2nd Edition, *Information Technology Equipment - Safety - Part 1: General Requirements.*

At the time of the publication of this ATIS Standard, the IEEE Telecommunication Safety Technical Committee (TSTC), in collaboration with other SDOs, is working to clarify and develop the requirements based on IEC TR-62102 and GR-1089-CORE.

4.2 Power over Ethernet (PoE)

PoE is a powering technique used over the existing Ethernet wiring link. IEEE standard 802.3af and 802.3at, which have both been replaced with IEEE 802.3-2012, are identified as Type 1 powering and Type 2 powering respectively within the IEEE 802.3 (2012) document. The IEEE 802.3at (Type 2) specification provides the guidelines for PoE+, which is a higher power level than the original PoE. Both

of these specifications allow the Ethernet wiring to carry both data and DC power. This removes the need for a local ac/dc power port for each individual Ethernet interface.

Here are two major advantages for PoE:

- The Ethernet PD (Powered Device) is not required to be placed next to localized power sources.
- Power cables are no longer required to be laid out for the remote Ethernet PDs.

In a PoE scheme, the device that receives the power is called the client device or PD and the device supplying the power is the Power Source Equipment (PSE). The IEEE 802.3af standard limits the PD power consumption to 12.95W and limits the PSE power outputs to 15.4W on a per Ethernet port basis. The network may contain patch panels and various connectors that cause some voltage and power loss. Therefore, the IEEE 802.3af standard limits the maximum PSE available current to 400mA per device connection and the PD current to 360mA. This standard takes into account line losses for maximum loop lengths of 100 meters, thereby allowing up to 57 V_{DC} from the PSE. The nominal level is 48 V_{DC}. The PoE+ (IEEE 802.3at) allows the PSE to deliver up to 30W and the PD to consume up to 25.5 W; with the PSE supplying up to a maximum of 600mA. PoE+ also requires the use of low resistance wiring (< 12.5 ohms per loop pair). CAT6 and CAT7 wiring always satisfies this requirement. CAT3, CAT5, and CAT5e sometimes satisfy this powering requirement, depending on the length of wire used. (For example, CAT5e is specified at 0.188 ohms per meter maximum.) CAT3 and CAT5 are not recommended for data rates greater than 10BASE-T.

Currently the IEEE Std 802.3-2012 defines two different types of PSEs and PDs that deliver and receive power over 2 wire pairs. A Type 1 PSE can source up to 15.4 W and a Type 1 PD can consume a maximum of 13W. A Type 2 PSE can source a maximum of 30W and a Type 2 PD can consume a maximum of 25.5 W. The industry is demanding higher power levels that would require power being supplied over 4 wire pairs. Two new power levels are being looked at in order to meet this demand, the first providing ~50 W to the PD, and the second providing 70 – 75 W to the PD. It is also desirable to use 4 pair PoE for new PDs that require lower power levels in order to minimize power losses in the Ethernet cables and in the connector interfaces. This will create two new types of PSEs and PDs. The IEEE 802.3 Ethernet Working Group (Task Force IEEE P802.3bt) is currently developing a standard that will provide guidelines for the deployment of these two new Types of PSEs and PDs.

Figures 4.7 and 4.8 show generic block diagrams for the implementation of 4 pair PoE. It is important to note that the IEEE 802.3-2012 standard states that a PSE can only supply power using alternative A or alternative B. It forbids transmitting power using both alternatives simultaneously. This conflicts with the requirements for 4 pair PoE and will have to be addressed in the next revision of the standard.

Proposals have been made for the PSE to use a single switch to enable power as well as for using two switches, one for each set of two power pairs. This is why figures 4.7 and 4.8 are drawn with four lines coming out of the PSE and four lines going into the PD. This has been viewed as an implementation issue and care is being taken to allow both PSE architectures. On the PSE side, each set of two lines could be connected together for a single switch implementation. In general, the four lines will be separate on the PD end since most PDs are designed with reverse polarity protection.

This power can be inserted from (1) an endpoint PSE or (2) a mid-span PSE (also known as a PoE injector). Legacy Ethernet systems most likely use a mid-span PSE method. This prevents having to re-work the entire network. For new installations, the endpoint PSE is the most economical and easiest installation choice. Power can be provided in one of three ways:

1. Over the same pair used for data signaling in 10BASE-T and 100BASE-T systems, or
2. Over the unused pair in 10BASE-T and 100BASE-T systems, or
3. Over a proprietary powering scheme (not covered by this standard).

Per the above PoE standards, the PoE powering is not normally active when a PD is disconnected, and during this time no continuous voltage is present. However, a voltage is applied periodically to poll the

presence of a PD. When a PD is detected, a handshake routine between the PSE and the PD initiates a power-on sequence.

For clarity, the following schematics do not show any resistor/capacitor networks (commonly referred to as “Bob Smith” type terminations) or chokes on the line side of the transformer or on any unused wire pair. Resistors, capacitors, chokes, and protection components on the PHY side of the transformer are not shown.

4.2.1 Mode A

Mode A power can be used with any of the Ethernet data rates. Mode A power is applied over the “active” data pair found in 10BASE-T or 100BASE-TX interfaces. In these type systems, two pairs are used for data delivery (RJ-45 pins: 1-2 and 3-6) and two pairs are unused (pairs 4-5 and 7-8). This is shown in Figure 4.3 below. The powered device receives its power from the voltage between two separate pairs. This combines the dc voltage with the signal over the transmit (TX) and receive (RX) pairs (simplex powering). The two center tap connections provide access to the dc power; and the dc voltage across any single pair (i.e., 1-2 or 3-6) remains at zero volts.

Mode A PoE

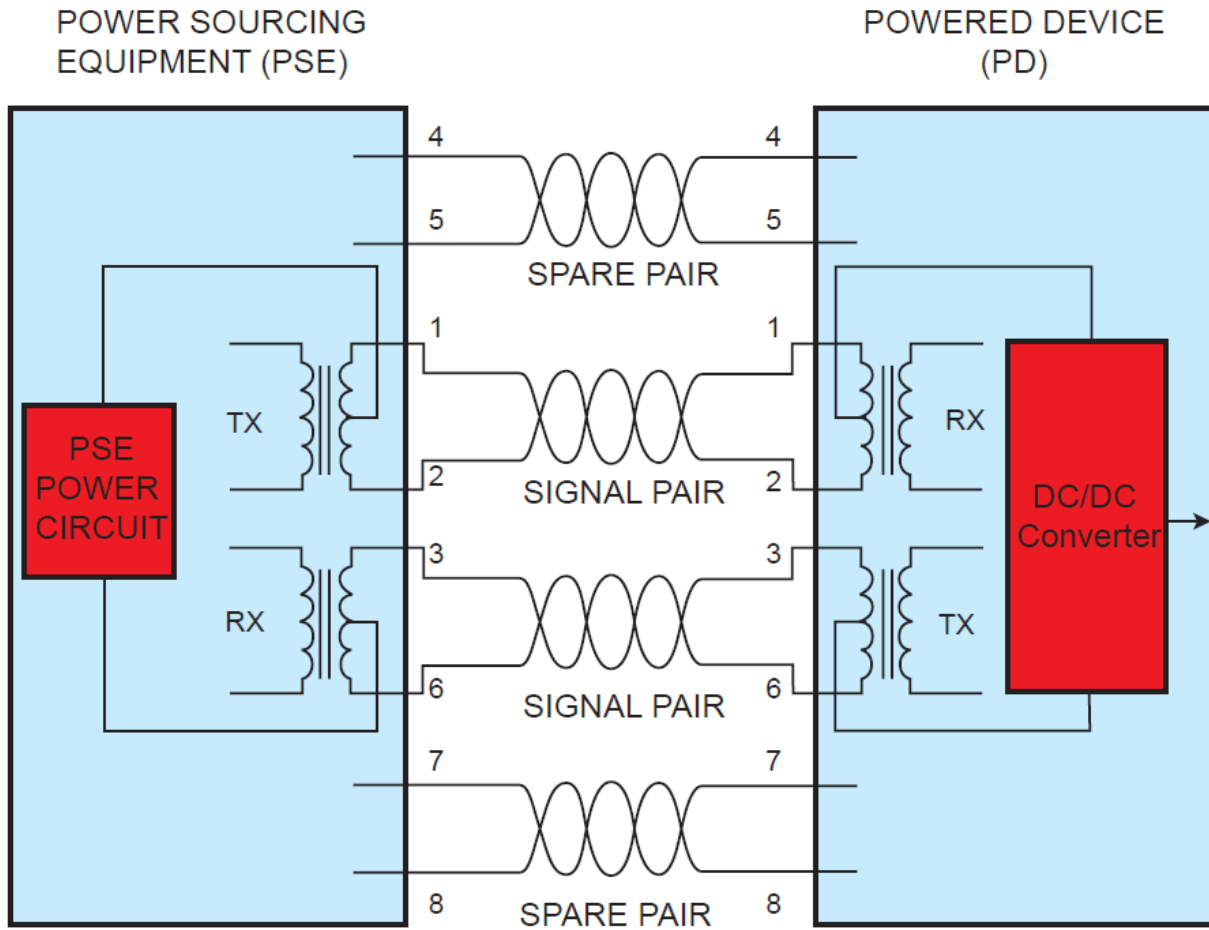

Figure 4.3 – Mode A for 10/100Base T

4.2.2 Mode B

Mode B power can be used with any of the Ethernet data rates. Mode B power is applied on pins 4-5 and 7-8 (pairs 3 and 4). 10/100BASE-T systems do not use these pairs for data. This is shown in Figure 4.4 below. In 1000BASE-T (GigE) and 10GigE applications, all wire pairs are used for data transfer. Therefore, Mode A or Mode B power is provided by the center taps of the transformer instead of unused pins.