

Specification for Offshore Pedestal Mounted Cranes

API SPECIFICATION 2C
SIXTH EDITION, MARCH 2004

EFFECTIVE DATE: SEPTEMBER 2004



**Helping You
Get The Job
Done Right.SM**

Specification for Offshore Pedestal Mounted Cranes

Upstream Segment

API SPECIFICATION 2C
SIXTH EDITION, MARCH 2004

EFFECTIVE DATE: SEPTEMBER 2004



**Helping You
Get The Job
Done Right.SM**

SPECIAL NOTES

API publications necessarily address problems of a general nature. With respect to particular circumstances, local, state, and federal laws and regulations should be reviewed.

API is not undertaking to meet the duties of employers, manufacturers, or suppliers to warn and properly train and equip their employees, and others exposed, concerning health and safety risks and precautions, nor undertaking their obligations under local, state, or federal laws.

Information concerning safety and health risks and proper precautions with respect to particular materials and conditions should be obtained from the employer, the manufacturer or supplier of that material, or the material safety data sheet.

Nothing contained in any API publication is to be construed as granting any right, by implication or otherwise, for the manufacture, sale, or use of any method, apparatus, or product covered by letters patent. Neither should anything contained in the publication be construed as insuring anyone against liability for infringement of letters patent.

Generally, API standards are reviewed and revised, reaffirmed, or withdrawn at least every five years. Sometimes a one-time extension of up to two years will be added to this review cycle. This publication will no longer be in effect five years after its publication date as an operative API standard or, where an extension has been granted, upon republication. Status of the publication can be ascertained from the API Standards department telephone (202) 682-8000. A catalog of API publications, programs and services is published annually and updated biannually by API, and available through Global Engineering Documents, 15 Inverness Way East, M/S C303B, Englewood, CO 80112-5776.

This document was produced under API standardization procedures that ensure appropriate notification and participation in the developmental process and is designated as an API standard. Questions concerning the interpretation of the content of this standard or comments and questions concerning the procedures under which this standard was developed should be directed in writing to the Director of the Standards department, American Petroleum Institute, 1220 L Street, N.W., Washington, D.C. 20005. Requests for permission to reproduce or translate all or any part of the material published herein should be addressed to the Director, Business Services.

API standards are published to facilitate the broad availability of proven, sound engineering and operating practices. These standards are not intended to obviate the need for applying sound engineering judgment regarding when and where these standards should be utilized. The formulation and publication of API standards is not intended in any way to inhibit anyone from using any other practices.

Any manufacturer marking equipment or materials in conformance with the marking requirements of an API standard is solely responsible for complying with all the applicable requirements of that standard. API does not represent, warrant, or guarantee that such products do in fact conform to the applicable API standard.

All rights reserved. No part of this work may be reproduced, stored in a retrieval system, or transmitted by any means, electronic, mechanical, photocopying, recording, or otherwise, without prior written permission from the publisher. Contact the Publisher, API Publishing Services, 1220 L Street, N.W., Washington, D.C. 20005.

FOREWORD

This specification is under the jurisdiction of the API Subcommittee on Standardization of Offshore Structures.

The purpose of this specification is to provide standards for offshore pedestal mounted cranes suitable for use in drilling and production operations.

This standard shall become effective on the date printed on the cover but may be used voluntarily from the date of distribution.

This edition of API Spec 2C supercedes the Fifth Edition dated April 1995. The number and nature of changes in this edition from the previous edition are such that marking the changes between the two editions is impractical.

API publications may be used by anyone desiring to do so. Every effort has been made by the Institute to assure the accuracy and reliability of the data contained in them; however, the Institute makes no representation, warranty, or guarantee in connection with this publication and hereby expressly disclaims any liability or responsibility for loss or damage resulting from its use or for the violation of any federal, state, or municipal regulation with which this publication may conflict.

Suggested revisions are invited and should be submitted to API, Standards department, 1220 L Street, NW, Washington, DC 20005.

CONTENTS

	Page
1 SCOPE.....	1
1.1 General.....	1
1.2 Safe Working Limits.....	1
1.3 Critical Components.....	2
1.4 Commentary.....	2
1.5 Record Retention.....	2
1.6 Manufacturer Supplied Documentation.....	2
2 REFERENCES.....	3
2.1 Standards.....	3
2.2 Other References.....	4
3 DEFINITIONS, ABBREVIATIONS, AND UNITS.....	4
3.1 Definitions.....	4
3.2 Abbreviations.....	8
3.3 Units.....	8
4 CRANE RATINGS.....	8
4.1 General.....	8
4.2 Load Rating and Information Charts.....	10
4.3 In-service Loads.....	12
4.4 Out-of-service Loads.....	15
4.5 Wind, Ice, and Seismic Loads.....	15
4.6 Gross Overload Conditions.....	17
5 ALLOWABLE STRESSES.....	17
5.1 General.....	17
5.2 Pedestal, King Post, and Platform Connection.....	18
5.3 Exceptions to the Use of the AISC Specification.....	18
5.4 Fatigue.....	18
5.5 Certification.....	18
6 DESIGN AUTHENTICATION AND TESTING.....	18
6.1 Design Authentication.....	18
6.2 Certification.....	19
6.3 Operational Tests.....	19
7 CRITICAL RIGGING COMPONENTS.....	19
7.1 General.....	19
7.2 Wire Rope.....	19
7.3 Wire Rope End Terminations.....	20
7.4 Sheaves.....	21
7.5 Load Block Assemblies.....	21
8 BOOM HOIST, LOAD HOIST, AND TELESCOPING BOOM MECHANISMS..	22
8.1 Hoists.....	22
8.2 Boom Control.....	25
8.3 Telescoping Boom Mechanisms.....	25

9	SWING MECHANISM	25
9.1	Swing Mechanism	25
9.2	Swing-circle Assembly	26
10	POWER PLANT	28
10.1	General	28
10.2	Exhaust Systems of Internal Combustion Prime Movers	28
10.3	Fuel Tanks	29
10.4	Hazardous Area Classifications	29
10.5	Isolation of Ignition Sources and Heated Surfaces	29
10.6	Diesel Air Intake Shut-off	29
11	CONTROLS	29
11.1	General	29
11.2	Power Plant Controls	29
11.3	Engine Clutch.	30
11.4	Crane Controls—Basic Lever Operating Arrangements.	30
12	CABS AND ENCLOSURES	31
12.1	General	31
12.2	Windows.	31
12.3	Doors	31
12.4	Cab Access	31
12.5	Platforms and Walkways	31
12.6	Rigging Access.	31
12.7	Noise Level	31
13	MISCELLANEOUS REQUIREMENTS AND EQUIPMENT.	31
13.1	Boom Equipment	31
13.2	Guards for Moving Parts	33
13.3	Clutch and Brake Protection	33
13.4	Lubricating Points and Fluid Fills	33
13.5	Hydraulic and Pneumatic Line Protection	34
13.6	Use of Environmentally Sensitive Materials	34
13.7	Anti Two-block	34
13.8	Personnel Emergency Load Lowering	34
13.9	Miscellaneous Equipment	34
14	MATERIAL REQUIREMENTS FOR STRUCTURAL COMPONENTS	34
14.1	Materials.	34
14.2	Traceability.	35
14.3	Fracture Toughness	35
14.4	Castings	35
14.5	Fasteners.	36
14.6	Plate	36
15	WELDING OF CRITICALLY STRESSED COMPONENTS	36
15.1	Standards	36
15.2	Welding Procedures	36
15.3	Welder Performance.	36
15.4	Welding Properties.	36

16	NONDESTRUCTIVE EXAMINATION OF CRITICAL COMPONENTS	36
16.1	Nondestructive Examination Procedures	36
16.2	Nondestructive Examination Personnel Qualifications.	36
16.3	Minimum Extent of Nondestructive Examination	36
16.4	Examples of Workmanship Standards.	37
17	MARKING	37
APPENDIX A	EXAMPLE LIST OF CRITICAL COMPONENTS.	39
APPENDIX B	COMMENTARY	41
APPENDIX C	MINIMUM PURCHASER-DEFINED REQUIREMENTS	49
APPENDIX D	API MONOGRAM MARKING	51
APPENDIX E	EXAMPLE CALCULATIONS	53

Tables

1	Summary of Design Parameters	9
2	Vertical Velocity for Dynamic Coefficient Calculations	15
3	Onboard Lift Dynamic Coefficients (C_v for General Method)	16
4	Crane Base Inclinations and Accelerations.	16
5	Vertical Dynamic Accelerations to be Applied to Crane Components	16
6	Sheave Groove Radius	22
7	Basic Four-lever Crane Control Function.	30
8	Basic Two-lever Crane Control Function (Option 1)	32
9	Basic Two-lever Crane Control Function (Option 2)	33
10	Acceptable Criteria Based on ASTM Radiographic Standards	35
11	Workmanship Standard Examples	37
B.4.3.1	General Method—Vessel Information	41
B.4.3.2	General Method Sample Design Value Calculations.	42
B.4.3.3	Minimum Required Hook Speeds at the Supply Boat Deck vs. Significant Wave Height.	43
B.5.4	Example Equivalent Fatigue Design Loads	44

Figures

1	Crane Assembly Types	1
2	Crane Nomenclature	2
3	Plots of Rated Loads for Various Operating Conditions	11
4	Methods of Securing Dead End of Rope when Using Wedge Sockets	20
5	Sheave Dimension.	21
6	Hoist Drum	24
7	Basic Four-lever Crane Control Diagram.	30
8	Basic Two-lever Crane Control Diagram (Option 1)	32
9	Basic Two-lever Crane Control Diagram (Option 2)	33
D.1	API Monogram Nameplate.	51

Specification for Offshore Pedestal Mounted Cranes

1 Scope

1.1 GENERAL

This specification details the requirements for design, construction, and testing of offshore pedestal mounted cranes. Offshore cranes are defined herein as pedestal mounted elevating and rotating lift devices of the types illustrated in Figure 1 for transfer of materials or personnel to or from marine vessels and structures. Offshore cranes are typically mounted on a fixed (bottom supported) or floating platform structure used in drilling and production operations. API Spec 2C is not intended to be used for the design, fabrication, and testing of davits and/or emergency escape devices. API Spec 2C is also not intended to be used for shipboard cranes or heavy lift cranes. Shipboard cranes are mounted on surface type vessels and are used to move cargo, containers, and other materials while the crane is within a harbor or sheltered area. Heavy lift cranes are mounted on barges or other vessels and are used in

construction and salvage operations within a harbor or sheltered area or in very mild offshore environmental conditions.

1.2 SAFE WORKING LIMITS

The intent of this specification is to establish safe working limits for the crane in anticipated operations and conditions. This is accomplished by establishing Safe Working Loads (SWLs) based on allowable unit stresses and design factors. Operation of the crane outside of the limits established by the manufacturer in accordance with the guidelines set forth in this document can result in catastrophic failure up to and including separating the entire crane and operator from the foundation. Compliance with the allowable stresses and design factors set forth in this specification does not guarantee that the crane will not be dismounted from its foundation in the event of a gross overload such as might occur in the event of snagging the supply boat.

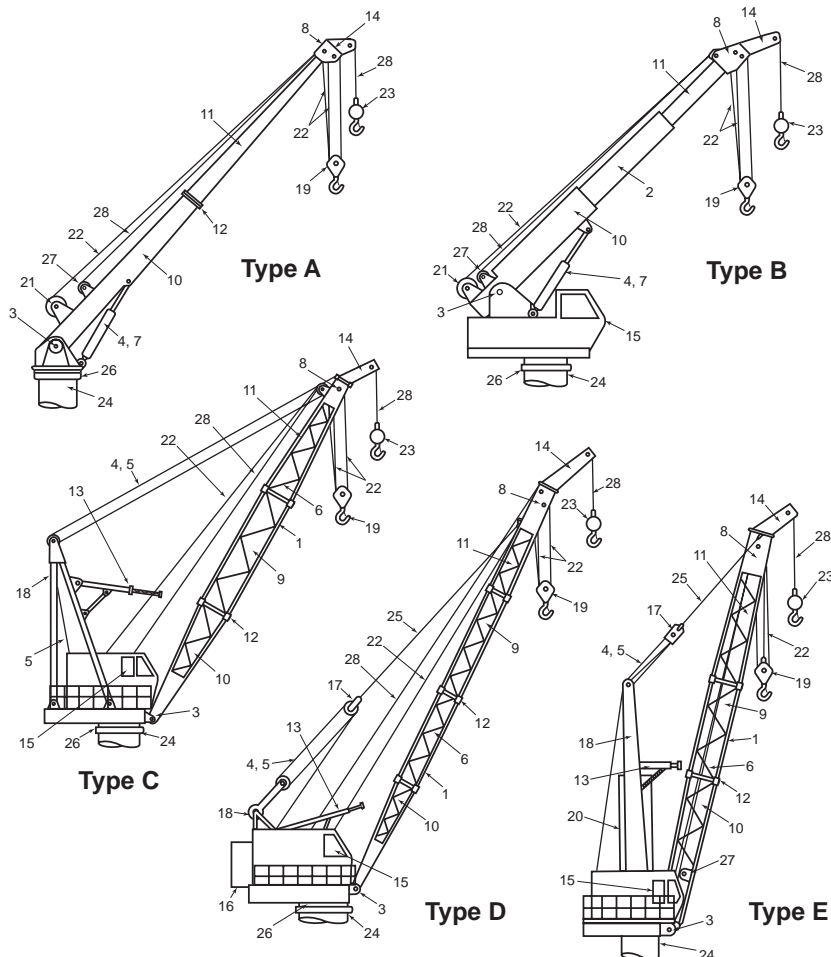

Figure 1—Crane Assembly Types

No.*	Component	Type, See Figure 1				
		A	B	C	D	E
1	Boom Chord	—	—	X	X	X
2	Boom Extension	—	X	—	—	—
3	Boom Foot Pin	X	X	X	X	X
4	Boom Hoist Mechanism	X	X	X	X	X
5	Boom Hoist Wire Rope or Boom Line	—	—	X	X	X
6	Boom Lacing	—	—	X	X	X
7	Boom Lift Cylinder	X	X	—	—	—
8	Boom Point Sheave Assembly or Boom Head	X	X	X	X	X
9	Boom Section, Insert	—	—	X	X	X
10	Boom Section, Lower, Base or Butt	X	X	X	X	X
11	Boom Section, Upper, Point or Tip	X	X	X	X	X
12	Boom Splice	X	—	X	X	X
13	Boom Stop	—	—	X	X	X
14	Boom Tip Extension or Jib	X	X	X	X	X
15	Cab	—	X	X	X	X
16	Counterweight	—	—	—	X	—
17	Floating Harness or Bridle	—	—	—	X	X
18	Gantry, Mast or A-frame	—	—	X	X	X
19	Hook Block	X	X	X	X	X
20	King Post or Center Post	—	—	—	—	X
21	Main Hoist Drum	X	X	—	—	—
22	Main Hoist Rope or Load Line	X	X	X	X	X
23	Overhaul Ball	X	X	X	X	X
24	Pedestal or Base	X	X	X	X	X
25	Pendant Line	—	—	—	X	X
26	Swing-circle Assembly	X	X	X	X	—
27	Whip Line or Auxiliary Hoist Drum	X	X	—	—	X
28	Whip Line or Auxiliary Hoist Rope	X	X	X	X	X

Note: * See Figure 1.

Figure 2—Crane Nomenclature

1.3 CRITICAL COMPONENTS

A critical component is any component of the crane assembly devoid of redundancy and/or auxiliary restraining devices whose failure would result in an uncontrolled descent of the load or uncontrolled rotation of the upper-structure. Due to their criticality, these components are required to have stringent design, material, traceability, and inspection requirements. The manufacturer shall prepare a list of all critical components for each crane. Appendix A contains an example list of critical components.

1.4 COMMENTARY

Further information and references on various topics contained in this specification are included in the Commentary found in Appendix B. The section numbers in Appendix B correspond to the section numbers of this specification. For example, Section 4.3 of this specification, entitled *In-service Loads*, corresponds to Section B.4.3 in Appendix B.

1.5 RECORD RETENTION

The manufacturer shall maintain all inspection and testing records for 20 years. These records shall be employed in a quality audit program of assessing malfunctions and failures for the purpose of correcting or eliminating design, manufacturing, or inspection functions, which may have contributed to the malfunction or failure.

1.6 MANUFACTURER SUPPLIED DOCUMENTATION

The manufacturer shall supply to the purchaser certain documentation for each crane manufactured. Unless otherwise agreed to by the purchaser, the documentation shall include:

1. Load and information charts per Section 4.2.
2. Crane foundation design forces and moments per Section 5.2.